

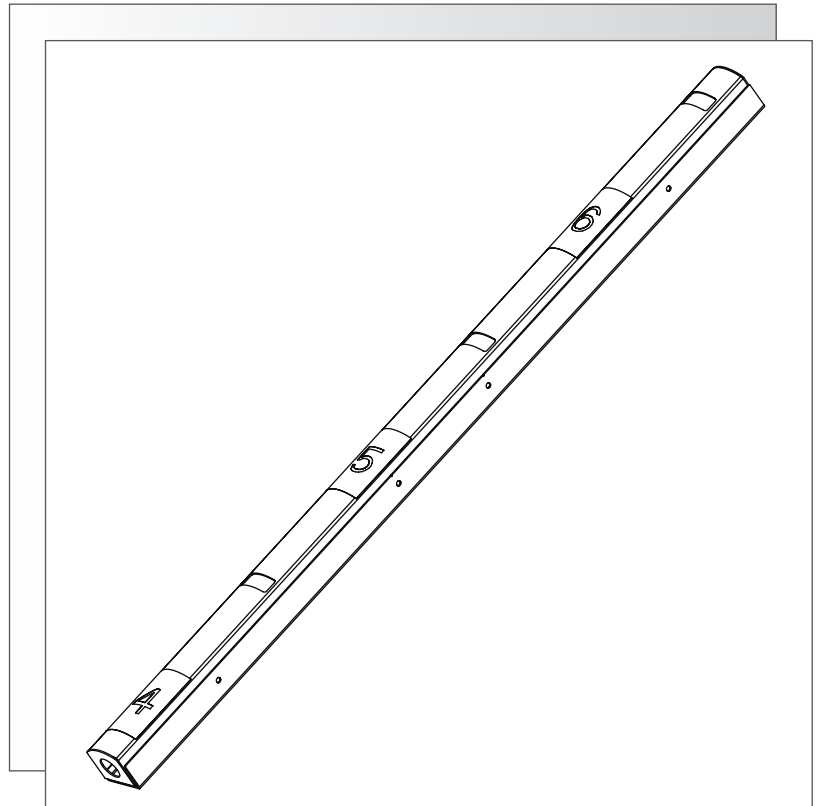

## HEIGHT STRIP CAMERA





## HC SERIES

**INSTALLATION AND OPERATING INSTRUCTIONS**  
**WWW.LINEARCORP.COM**

## IMPORTANT SAFEGUARDS

1. Read Instructions - All the safety and operating instructions should be read before the unit is operated.
  2. Retain Instructions - The safety and operating instructions should be retained for future reference.
  3. Heed Warnings - All warnings on the unit and in the operating instructions should be adhered to.
  4. Follow Instructions - All operating and use instructions should be followed.
  5. Cleaning - Unplug the unit from the outlet before cleaning. Do not use liquid cleaners or aerosol cleaners. Use a damp cloth for cleaning.
  6. Attachments - Do not use attachments not recommended by the product manufacturer as they may cause hazards.
  7. Accessories - Do not place this unit on an unstable stand, tripod, bracket, or mount. The unit may fall, causing serious injury to a person and serious damage to the unit. Use only with a stand, tripod, bracket, or mount recommended by the manufacturer or sold with the product. Any mounting of the unit should follow the manufacturer's instructions and should use a mounting accessory recommended by the manufacturer.
-  An appliance and cart combination should be moved with care. Quick stops, excessive force, and uneven surfaces may cause the appliance and cart combination to overturn.
8. Ventilation - Openings in the enclosure, if any, are provided for ventilation, to ensure reliable operation of the unit, and to protect it from overheating. These openings must not be blocked or covered. This unit should not be placed in a built-in installation unless proper ventilation is provided or the manufacturer's instructions have been adhered to.
  9. Power Sources - This unit should be operated only from the type of power source indicated on the marking label. If you are not sure of the type of power supply you plan to use, consult your dealer or local power company. For units intended to operate from battery power or other sources, refer to the operating instructions. This equipment is to be isolated from the mains supply by a limited power source as specified in EN60950:1992 Clause 2.11.
  10. Grounding or Polarization - This unit may be equipped with a polarized alternating-current line plug (a plug having one blade wider than the other). This plug will fit into the power outlet only one way. This is a safety feature. If you are unable to insert the plug fully into the outlet, try reversing the plug. If the plug should still fail to fit, contact your electrician to replace your obsolete outlet. Do not defeat the safety purpose of the polarized plug.  
Alternately, this unit may be equipped with a 3-wire grounding-type plug, a plug having a third (grounding) pin. This plug will only fit into a grounding-type power outlet. This is a safety feature. If you are unable to insert the plug into the outlet, contact your electrician to replace your obsolete outlet. Do not defeat the safety purpose of the grounding-type plug.
  11. Power Cord Protection - Power supply cords should be routed so that they are not likely to be walked on or pinched by items placed upon or against them, paying particular attention to cords and plugs, convenience receptacles, and the point where they exit from the appliance.
  12. Power Lines - An outdoor system should not be located in the vicinity of overhead power lines or other electric light or power circuits or where it can fall into such power lines or circuits. When installing an outdoor system, extreme care should be taken to keep from touching such power lines or circuits as contact with them might be fatal. U.S.A. models only - refer to the National Electrical Code Article 820 regarding installation of CATV systems.
  13. Overloading - Do not overload outlets and extension cords as this can result in a risk of fire or electric shock.
  14. Object and Liquid Entry - Never push objects of any kind into this unit through openings, as they may touch dangerous voltage points or short out parts that could result in a fire or electric shock. Never spill liquid of any kind on the unit.
  15. Servicing - Do not attempt to service this unit yourself as opening or removing covers may expose you to dangerous voltage or other hazards. Refer all servicing to qualified service personnel.
  16. Damage Requiring Service - Unplug the unit from the outlet and refer servicing to qualified service personnel under the following conditions:
    - a. When the power supply cord or plug is damaged.
    - b. If liquid has been spilled or objects have fallen into the unit.
    - c. If the unit has been exposed to water and/or inclement weather (rain, snow, etc.).
    - d. If the unit does not operate normally by following the operating instructions. Adjust only those controls that are covered by the operating instructions, as an improper adjustment of other controls may result in damage and will often require extensive work by a qualified technician to restore the unit to its normal operation.
    - e. If the unit has been dropped or the cabinet has been damaged.
    - f. When the unit exhibits a distinct change in performance--this indicates a need for service.
  17. Replacement Parts - When replacement parts are required, be sure the service technician has used replacement parts specified by the manufacturer or have the same characteristics as the original part. Unauthorized substitutions may result in fire, electric shock, or other hazards.
  18. Safety Check - Upon completion of any service or repairs to this unit, ask the service technician to perform safety checks to determine that the unit is in proper operating condition.
  19. Coax Grounding - If an outside cable system is connected to the unit, be sure the cable system is grounded. U.S.A. models only--Section 810 of the National Electrical Code, ANSI/NFPA No.70-1981, provides information with respect to proper grounding of the mount and supporting structure, grounding of the coax to a discharge unit, size of grounding conductors, location of discharge unit, connection to grounding electrodes, and requirements for the grounding electrode.
  20. Lightning - For added protection of this unit during a lightning storm, or when it is left unattended and unused for long periods of time, unplug it from the wall outlet and disconnect the cable system. This will prevent damage to the unit due to lightning and power line surges.

## SAFETY PRECAUTIONS

	<b>CAUTION</b> RISK OF ELECTRIC SHOCK. DO NOT OPEN!	
<b>CAUTION: TO REDUCE THE RISK OF ELECTRIC SHOCK, DO NOT REMOVE COVER (OR BACK). NO USER SERVICEABLE PARTS INSIDE. REFER SERVICING TO QUALIFIED SERVICE PERSONNEL.</b>		

	<b>This symbol indicates the presence of uninsulated “dangerous voltage” within the product’s enclosure. This may constitute a risk of electric shock.</b>
---	--

	<b>The user should consult the operating and maintenance (servicing) instructions in the literature accompanying the appliance.</b>
---	---

	<b>Attention: Installation should be performed by qualified service personnel only in accordance with the National Electrical Code or applicable local codes.</b>
---	---

**Power Disconnect.** Units with or without  **ON-OFF** switches have power supplied to the unit whenever the power cord is inserted into the power source; however, the unit is operational only when the **ON-OFF** switch is in the **ON** position. The power cord is the main power disconnect for all units.

## 1 UNPACKING

Unpack carefully. This is electromechanical equipment and should be handled with care.

Check for the following items:

- Verify the unit model number.
- Verify that parts listed below have been included.

**HC1CH30-6xx** - Height Strip w/ one 650TVL color camera and 3.0mm lens.

### **Hardware Kit**

- 5 x Cable Ties
- 5 x Cable Tie Mounts
- 3 x Plastic Wall Anchor
- 3 x No. 8 cross recessed self-tapping screw, 1-1/2” length
- 1 x Barrel Plug Connector, 2.1mm pin, 36” length, stripped leads
- 1 x 12VDC 0.5 Amp Power Adapter, 6-foot cord

**CAM-HC1CH30-6** - Accessory 650TVL color camera w/ 3.0mm fixed lens

### **Hardware Kit**

- 1 x 12VDC 0.5 Amp Power Adapter, 6-foot cord
- 1 x M3 Nylon Lock Nut
- 1 x Flat Washer

**MT-HC** – Accessory Wall Bracket to turn the Height Strip 90° Left or Right

- 3 x M4 Screw, Pan Head Cross Recessed
- 3 x M4 Lock Nut

### **Equipment Required**

- 5.5mm or 7/32-inch Nut Driver (or Socket)
- 7.0mm or 9/32-inch Nut Driver (or Socket)
- #2 Cross Recessed Screwdriver
- Wire Cutters / Scissors
- Level
- Drill with 3/8” bit
- Optional: Step drill bit or 1/8”, 3/32”, 3/16”, 1/4”, 3/8” bits
- Optional: De-burr tool

**Note:** Optional items listed above are for use with side-mounted cameras. See Installation section.

If an item appears to have been damaged in shipment, replace it properly in its carton and notify the shipper. If any items are missing, notify Aigis Mechnronics Sales Representative or Customer Service. The shipping carton is the safest container in which the unit may be transported. Save it for possible future use. Verify that the parts listed as follows have been included.

## 2 SERVICE

If the unit ever needs repair service, the customer should contact Aigis Mechtronics for return authorization and shipping instructions.

## 3 CARE AND MAINTENANCE

Clean the viewing window(s) as needed with a mild, non-abrasive detergent in water and a soft cloth. DO NOT use alcohol based cleaners to clean the viewing window.

## 4 DESCRIPTION

The HC Series of Height Strip camera housings are intended to improve in-store security in two ways. First, when installed next to the main entrance of a store, cameras within the store will capture a subject's height when exiting as he or she passes the brightly colored labels. Second, the Height Strip's on-board camera will provide a facial shot of the subject as he or she exits. Each Height Strip unit can support up to five (5) Color Hi-Resolution cameras. Up to three (3) cameras can be oriented to look forward through the curved viewing windows and can be adjusted left or right of center. Up to an additional two (2) cameras can be turned 90° perpendicular to look directly across the doorway and provide a profile shot of the subject. Any cameras looking through the viewing windows can be adjusted 22° left and right of center. Side-viewing cameras cannot be adjusted, and require the installer to drill a small hole in the side of the Height Strip.

An accessory L-bracket (p/n MT-HC) can be installed to turn the entire Height Strip 90° in either direction to orient the viewing windows parallel to the wall. This provides a profile shot of customers entering and exiting a store.

The camera(s) can be adjusted up to 22° left or right of center to adjust the view slightly into or out of the store.

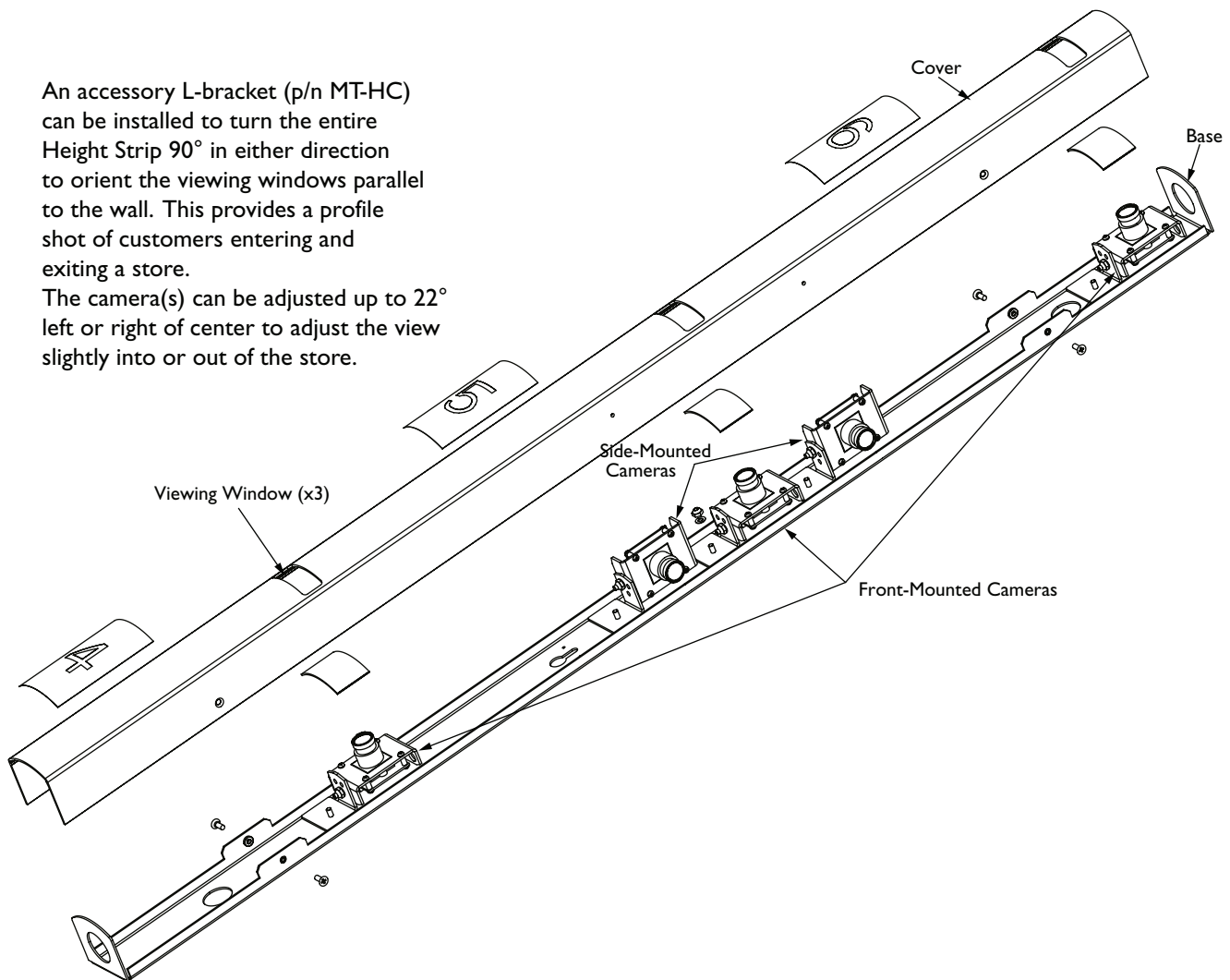

Figure 1 Height Strip Camera

## 5 VOLTAGE & MAX WATTAGE

Color Camera 95mA (Max) @ 12VDC



**Warning:** All cameras are powered by DC voltage. If you are running DC voltage over a pair of wires, be careful of polarity. A barrel plug connector with flying leads is provided. The white/black wire corresponds to the core of the connector, and should be supplied with +12VDC voltage. The black wire corresponds to the shell of the connector, and should be used as DC ground.

## 6 DISASSEMBLY

### 6.1 Cover Removal

1. Remove the unit from its packaging. Cut open one end of the plastic tubing covering the Height Strip. Leave the window masks in place.
2. Using a No. 2 Cross Recessed screwdriver, remove all four screws that secure the cover (see **Figure 2**). Remove cover.

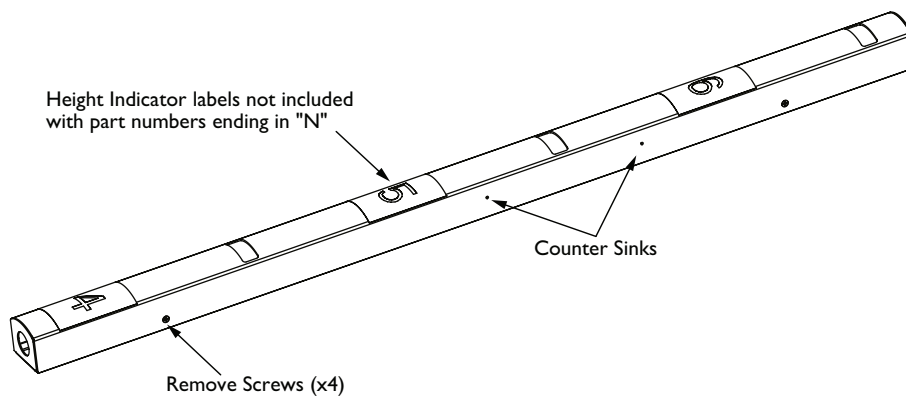

**Figure 2 Assembled Height Strip Camera**

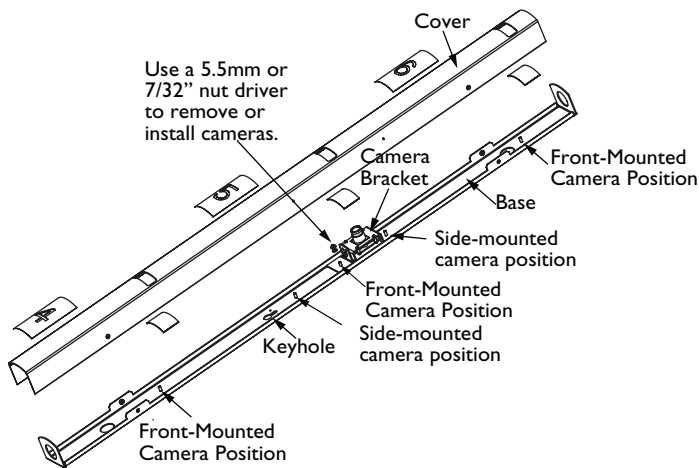

**Figure 3 Internal View Camera Positions**

### 6.2 Camera Removal/Relocation, and Installing Accessory Camera

1. Each Height Strip ships from the factory with a single camera installed that looks through the viewing window located at the 5-1/2 foot mark. Two other viewing windows are provided at the 4-1/2 foot mark and 6-1/2 foot.
2. To relocate the existing camera, use a 5.5mm (or 7/32") nut driver to remove the M3 nut that attaches the camera bracket to the base (see **Figure 4**). Remove the camera and bracket from the base.
3. When installing a new camera or relocating the existing camera, always refer to the keyhole to ensure the camera is not installed upside down. The circular part of the keyhole should face the ground and the slot should face the ceiling. Always install the camera *above* the desired pem stud in the base.
4. Accessory cameras require the own power supply. Do not double terminate the supplied power adapter.
5. Install all front-facing cameras before proceeding to the next section.
6. To install a side-mounted camera, refer to the **“Installation – Side-Mounted Cameras”** section.

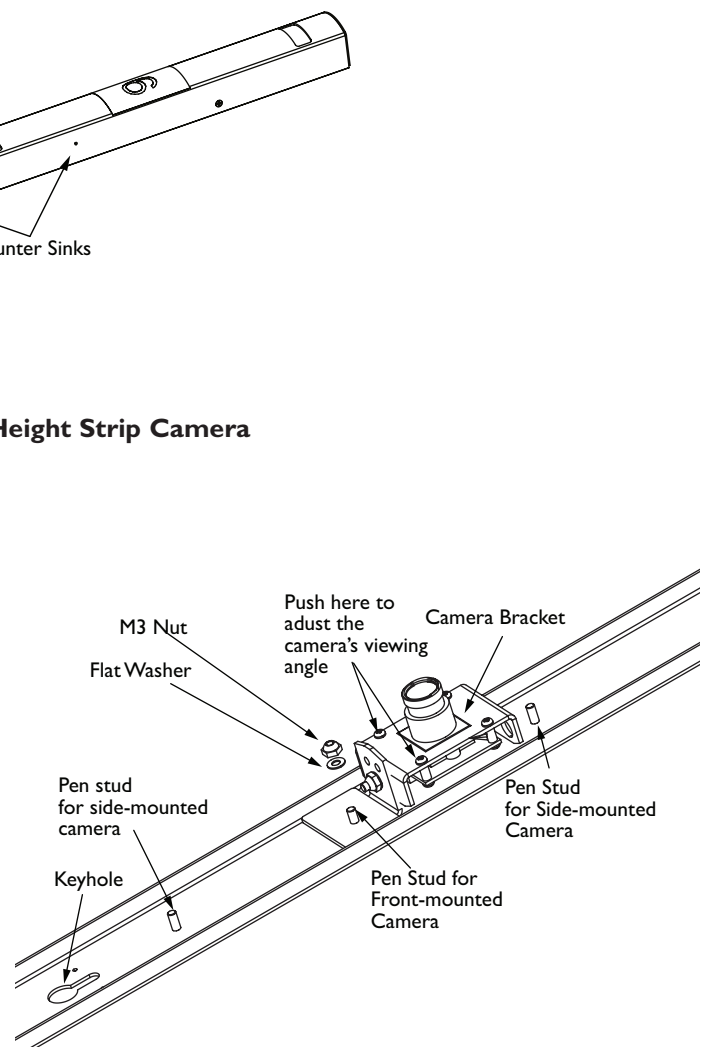

**Figure 4 Close up View Camera Position**

## 7 INSTALLATION

### 7.1 Side-mounted cameras

**Note:** If NOT using the side-mounted camera feature of the Height Strip, proceed to the next applicable section.

1. Refer to **Figure 5** when side-mounting a camera.
2. Two positions are available for side-mounted cameras, one directly below and one directly above the center mounting location (5.5-foot mark). Select which mounting location you prefer.
3. Determine which direction the camera should face once installed. Remember to use the keyhole as a guide. The round part of the keyhole faces the ground.
4. Change the camera bracket's pivot point. Remove the M3 nut, flat washer, and nylon washer from the camera bracket using a 5.5mm (7/32") nut driver or socket.

**Note:** the nylon washer is located between the camera bracket and the "L" bracket. Be careful not to lose it.

5. Place the nylon washer over the pem stud of the camera bracket (a.k.a. camera bracket axis), then insert the pem stud into the side of the "L" bracket OPPOSITE the direction of the camera. Replace the flat washer and M3 nut and tighten (see "Note" in **Figure 5**).
6. Before drilling, remove the camera bracket and "L" bracket from the base. Hold the cover next to the base. Locate the two small indentations (countersinks) on each side of the cover. Mark the countersink that corresponds to your mounting location.

7. Fit the cover back over the base and tighten down the four (4) M3 screws to secure.
8. Locate the marked countersink in the cover.
9. Drill out an appropriate sized hole in the Height Strip cover using the following guidelines:

#### **Color Camera**

- a. If using a step drill bit (recommended), drill the hole to 3/8-inch diameter.
- b. If using standard drill bits, first use a 1/8-inch bit, then 1/4-inch bit, then a 3/8-inch bit. This will minimize chatter and help ensure a round hole is drilled.

10. Remove the four M3 screws to remove the cover. Remove any burrs from the inside of the cover.
11. Install the camera in the side-mounting location using a flat washer and M3 nut. Proceed to the next applicable section to complete the installation.

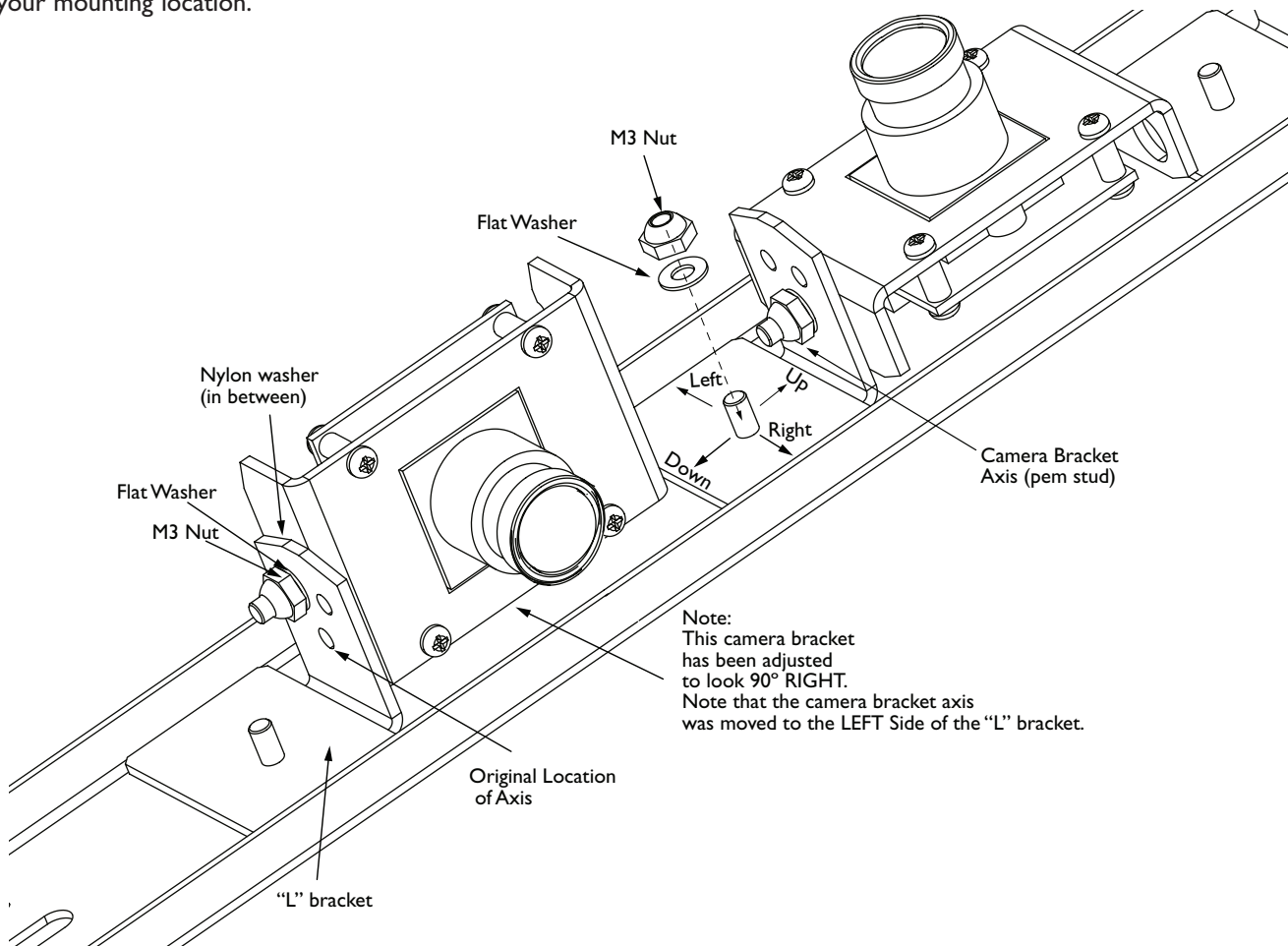

**Figure 5 Side Mounted Cameras**

## 7.2 Installing the Unit onto a Mullion or Metal Doorframe

1. Measure from the floor to the 5-foot mark on the mounting surface. Make a mark at 5 feet.
2. Drill a 3/16" hole in the center of the mullion at the 5-foot mark.
3. Remove a #8 self tapping screw and a wall anchor from the hardware kit.
4. Insert the wall anchor into the hole and tighten the self tapping screw until only a 1/8" gap remains under the screw head.
5. Hang the base of the Height Strip onto the screw using the keyhole. Refer to **Figure 6**. The two small holes near the top of the keyhole indicate the 5-foot mark. Align these holes with the screw and hand-tighten the screw to hold the base.
6. Use a level to ensure the Height Strip base is held vertically.
7. Use the base as a template to mark the hole location of the other two mounting holes, as well as mark the desired through-hole(s) for the power and video cables.
8. Refer to **Figure 7** regarding cable entry into the unit.
9. If running cables from the top of the mullion down to the unit, use the cable through-hole near the 6-foot mark. If running cables up to the unit from the floor, use the cable through-hole below the 4-foot mark. Note: If running cables through the knockouts on the top or bottom of the unit, disregard this step.
10. Unscrew the base and set aside. Drill out the remaining two mounting holes (3/16" drill bit) and insert the remaining wall anchors.
11. At the desired through-hole location(s), drill a hole in the mullion wide enough to accept the customer-provided power and video cables.
12. Feed the cables down into the mullion and fish them out of the through-hole.
13. Hang the Height Strip back on the mounting screw in the mullion and feed the power and video cables into the unit.
14. Align the base with the 5-foot mark as in Step 5 of this section and tighten the screw.
15. Insert the remaining two self tapping screws into the remaining mounting holes and tighten to secure the base to the mullion.
16. Terminate the ends of the customer-supplied cables as required, and connect power and video cables to the camera(s). Be sure to supply 12VDC with the correct polarity to the camera. The center pin (black/white wire) should be connected to +12VDC, and the shell of the connector (black wire) should be connected to DC Ground.
17. Use the cable ties and tie wrap mounts provided in the hardware kit to provide strain relief for the customer-supplied cables inside the Height Strip.
18. Orient the camera(s) left or right as desired. Turn the cameras by pushing on the lower part of the camera bracket (closest to the camera bracket axis).
19. Check the insides of the viewing windows (see **Figure 4**) for any dust or debris. Clean with a Kimwipe™ tissue, if necessary.
20. Replace the cover and secure with the four M3 flathead screws.

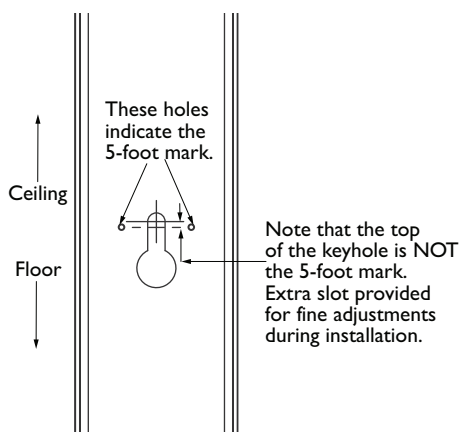

**Figure 6 Keyhole**

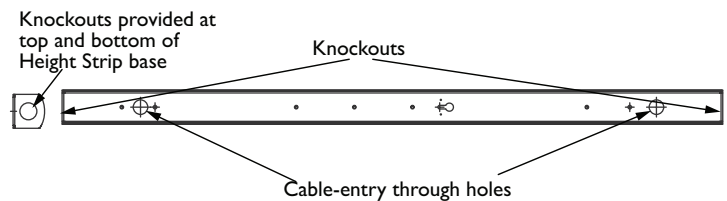

**Figure 7 Cable Entry**

### 7.3 Installing the Unit onto a Solid Wall

1. Refer to steps 1 to 6 above. Replace fasteners and wall anchors from the hardware kit with customer-supplied components as desired. The through-hole size for the wall mounts is sized for a #8 screw (approximately 0.175" diameter).
2. Use the base as a template to mark the hole location of the other two mounting holes. Remove the base from the wall and drill the remaining two mounting holes (3/16" drill bit).
3. Insert wall anchors into the holes in the wall, then place the Height Strip base back onto the mounting screw in the wall. Align the base with the 5-foot mark as in Step 5 of the previous section. Tighten the remaining mounting screws to secure the Height Strip base to the wall.
4. Knockouts are provided at the top and bottom of the unit for cable entry and conduit fittings.
5. Remove the desired knockout by pushing it into the base with a screw driver, then bending it back and forth until it snaps off.
6. Insert an appropriate conduit fitting into the hole, then run the customer-supplied power and video cables into the conduit fitting.
7. Refer to Step 14 of the previous section when connecting video and power cables to the camera.
8. Follow steps 15 – 18 of the previous section to complete the installation.

### 7.4 Installing the Unit using the Accessory Wall Bracket (MT-HC)

**Note:** cable entry can only be accomplished via the knockouts at the top or bottom of the Height Strip when using the MT-HC wall bracket.

1. Refer to **Figure 8** and **Figure 9** when installing this accessory.
2. Measure from the floor to the 5-foot mark on the mounting surface. Make a mark at 5 feet.
3. The side of the MT-HC with the rubber pads and notches, see **Figure 9**, near the center through-holes is the side that gets screwed to the wall. Always use the *lower* of the two center through-holes as your 5-foot mark reference. The Height Strip can be mounted facing either left or right of the accessory bracket by spinning the bracket 180°.
4. Orient the bracket as appropriate for your installation. Line up the notch of the lower through hole with the 5-foot mark.
5. Use the MT-HC bracket as a template to mark the mounting hole locations.
6. Drill 3/16" holes in the mounting surface if using the anchors and screws from the Height Strip's hardware kit. Drill an appropriate size hole if using other fasteners.
7. Insert wall anchors into the holes and secure the MT-HC to the mounting location using the screws.

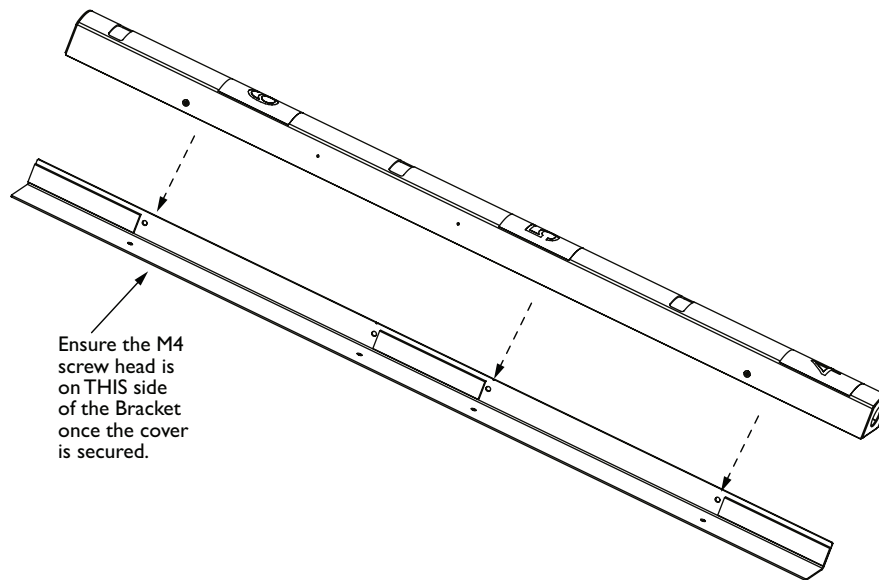

**Figure 8 Accessory Wall Bracket (MT-HC)**



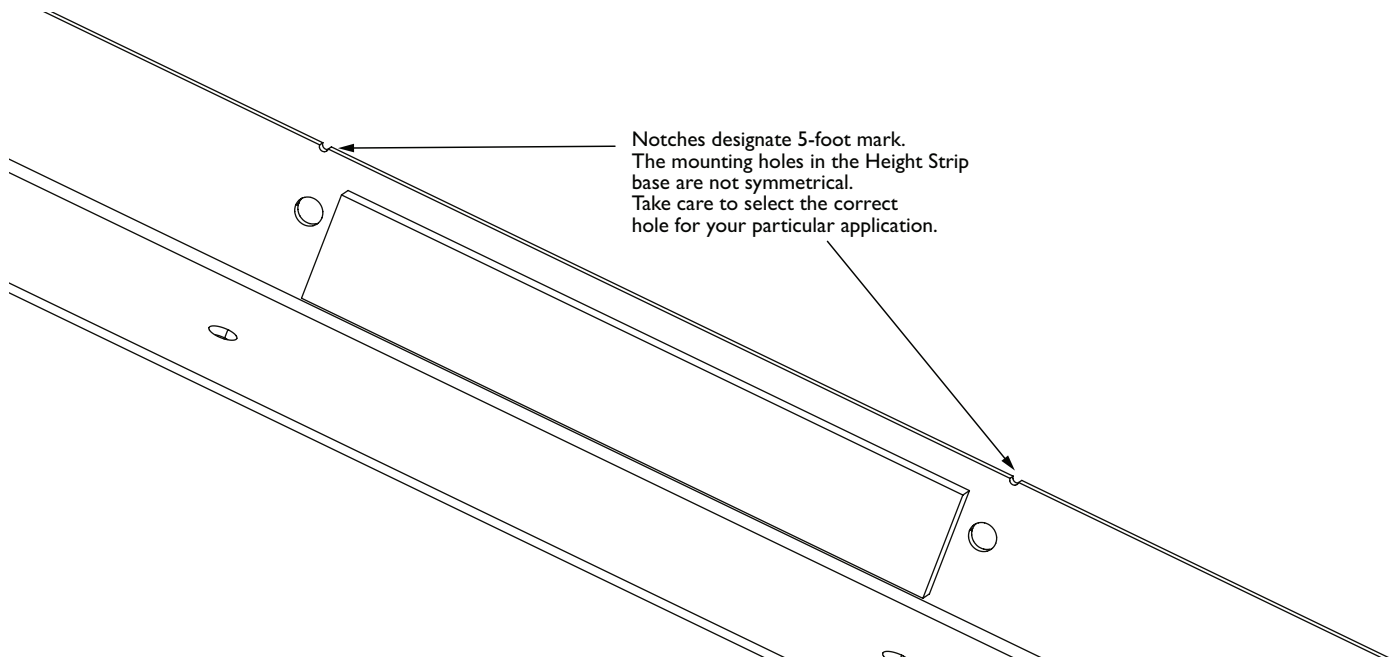
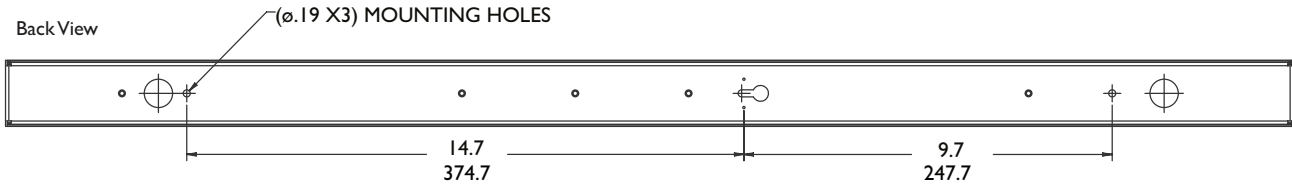

**Figure 9**

8. Remove the cover from the Height Strip by removing the four (4) cross-recessed screws.
9. Orient the Height Strip base as desired. Secure the base to the MT-HC accessory bracket using three (3) M4 screws and three (3) M4 nuts from the hardware kit sent with the MT-HC.
10. Ensure that the heads of the screws will be outside the unit and the nuts will be inside the unit once the cover is replaced.
11. Tighten the screws using a cross recessed screwdriver and a 7mm (9/32") socket or nut driver.
12. Knockouts are provided at the top and bottom of the unit for cable entry and conduit fittings.
13. Remove the desired knockout by pushing it into the base with a screw driver, then bending it back and forth until it snaps off.
14. Insert an appropriate conduit fitting into the hole, then run the customer-supplied power and video cables into the conduit fitting.
15. Terminate the ends of the customer-supplied cables as required, and connect power and video cables to the camera(s). Be sure to supply 12VDC with the correct polarity to the camera. The center pin (black/white wire) should be connected to +12VDC, and the shell of the connector (black wire) should be connected to DC Ground.
16. Use the cable ties and tie wrap mounts provided in the hardware kit to provide strain relief for the customer-supplied cables inside the Height Strip.
17. Orient the camera(s) left or right as desired. Turn the cameras by pushing on the lower part of the camera bracket (closest to the camera bracket axis).
18. Check the insides of the viewing windows for any dust or debris. Clean with a Kimwipe™ tissue, if necessary.
19. Replace the cover and secure with the four M3 flathead screws to complete the installation.

# DIMENSIONAL OUTLINES

Back View



Side View

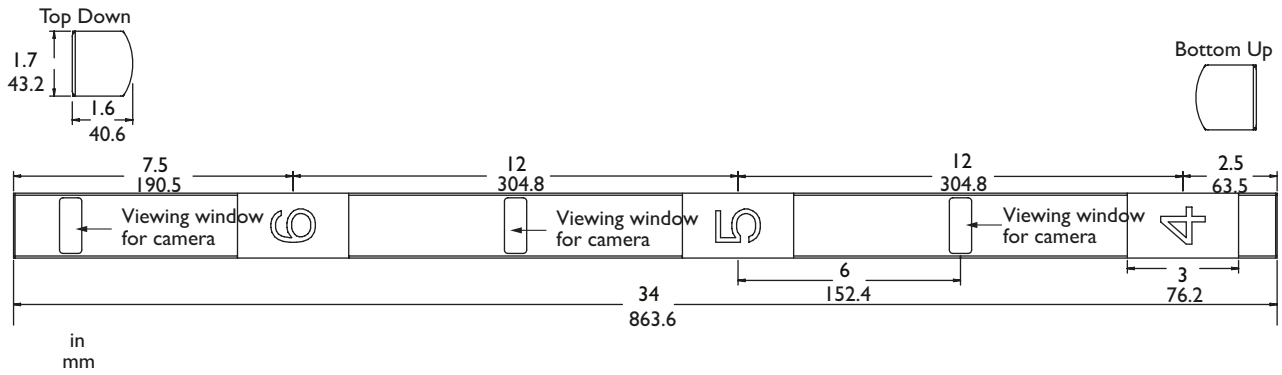
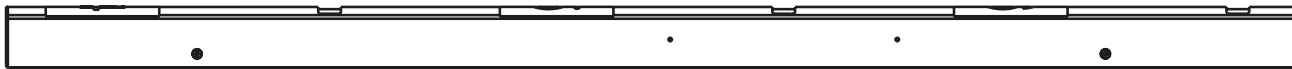





1950 Camino Vida Roble, Suite 150  
Carlsbad, CA 92008  
Tel: 760.438.7000 800.421.1587  
[www.aigismech.com](http://www.aigismech.com) • [www.linearcorp.com](http://www.linearcorp.com)

100 0266 002 AIG 02/12

Data subject to change without notice.

Copyright © 2012 Linear LLC